

PEARL®

EASY HAMMER® TROLLEY MANUAL



Tile stripper and
jackhammer sold
separately.

#PA01HT Hammer Trolley for:

- Bosch® 11335K
- Dewalt® D25960K
- Hitachi® H65SD2
- Milwaukee® 5337-21
- Makita® HM1317CB
- Makita® HM1307CB

#PA01HTB Hammer Trolley for:

- Bosch® Brute BH2760 65 lbs.

#PA01HTH Hammer Trolley for:

- Hilti® TE1000
- Hilti® TE1500

#PA01HTM Hammer Trolley for:

- Makita® HM1810 65 lbs.
- Special Order Only



WARNING: This product can potentially expose you to chemicals that are known to the State of California to cause cancer and birth defects or other reproductive harm. For more information, go to: www.P65Warnings.ca.gov

EASY HAMMER®

TABLE OF CONTENTS

INTRODUCTION	3
Key Terms	3
Disclaimer	3
PRODUCT INFORMATION	3
Safety Information	3
Safety Stickers	3
Warranty	4
Product Description and Specifications	4
INSTRUCTIONS FOR USE	5
STEP 1 - Fitting A Jack Hammer	5-6
STEP 2 - Using the Hammer Trolley	7
STEP 3 - Servicing the Hammer Trolley	7
APPENDIX	8
Parts Breakdown	8-9
Block Set Part Selection	10
Sales and Repairs	11
Tile Strippers	11
Jack Hammer Manual (When Purchased)	11

INTRODUCTION

This manual is designed to provide the user with the information required to operate and maintain the Easy Hammer® Trolley correctly and safely.



CAREFULLY READ AND FOLLOW ALL INSTRUCTIONS PROVIDED BY THE EASY HAMMER® MANUFACTURER.

KEY TERMS



1. READ CAREFULLY:

Refers to important information that should be paid careful attention.



2. CAUTION:

Indicates a situation that may cause injury or damage to the machine if the user does not follow the instructions.



3. WARNING:

Indicates a situation that may cause injury or death if the user does not follow the instructions correctly.



4. DANGER:

Indicates a situation that will cause injury or death if the user does not follow the instructions as written.



5. PROHIBITED:

Identifies actions that should never be carried out by anyone interacting with the machine.

DISCLAIMER

PEARL®, and its affiliates, takes no responsibility for any damage, injury or death resulting from the incorrect or unsafe use of this machine. Use of this machine should be undertaken by competent persons only. It is the operators' responsibility to ensure that the following safety procedures are followed.

PRODUCT INFORMATION

Throughout this document there are several safety warnings. The user should read through this complete document before using the Easy Hammer® Trolley.

SAFETY INFORMATION



1. READ CAREFULLY:

Ensure you read all information contained in this manual before using the Easy Hammer® Trolley.



2. READ CAREFULLY:

Ensure you read the manual and safety instructions for the Jack Hammer and other components that are part of this unit. See Appendix for more information.



3. DANGER:

Always wear the recommended personal protective equipment.



4. PROHIBITED:

Never expose the machine to moisture or rain.

There is a safety and information panel provided on the front of the Easy Hammer® Trolley to alert the user of potential safety risks/hazards. Please read and adhere to all instructions on the Unit.

SAFETY STICKERS



1. PROHIBITED:

It is forbidden to remove any safety or instructional stickers or panels from the Easy Hammer® Trolley.



2. READ CAREFULLY:

Read all safety and instructional stickers displayed on each component of the Easy Hammer® Trolley.

WARRANTY

1. PEARL® provides a Limited One Year Warranty that applies to Easy Hammer® Trolley only (this excludes the Jack Hammer and any other attachments and consumables).
2. Warranty does not cover wear and tear, breakage, misuse or theft. Warranty coverage is at the manufacturer's discretion.
3. Any unauthorized repair or part replacement will void warranty. Refer to manufacturer for all repairs.
4. Regular service must be carried out by competent persons only; failure to comply will void warranty.
5. Jack Hammer (where purchased) is to be covered by original manufacturer. See appendix.
6. Warranty does not cover consumables. Warranty does not cover attachments.

PRODUCT DESCRIPTION AND SPECIFICATIONS

The versatile Easy Hammer® packs a punch, saving you a lot of hard work and effort. Let the Easy Hammer® take the workload off your back!

No more struggling or bending trying to handle heavy hammers, the Easy Hammer® takes the pain out of demolition and renovation.

The Easy Hammer® enables your demolition hammer to lift most types of linoleum and tile, break rocks and blocks, crack concrete and sandstone, all with a minimum of effort.

With a wide range of angles the Easy Hammer® adapts to any situation with maximum leverage.

FEATURES

- Durable zinc-coated frame
- Angle adjustment – with huge angle range
- Choice of popular brand hammers; will suit most hammers
- Anti-vibration ergonomic design
- Large wheels

TABLE 2: #PA01HT Product Specifications

HEIGHT WHEN RAISED	1100mm / 43.3"
HEIGHT WHEN LOWERED	600mm / 23.6"
OVERALL WIDTH	510mm / 20.1"
OVERALL LENGTH	1100mm / 43.3"
ANGLE OF ADJUSTMENT	73° (93° closed) (20° open)
WEIGHT (WITHOUT JACKHAMMER)	28kg / 61.8lb

INSTRUCTIONS FOR USE



DO NOT OPERATE THE EASY HAMMER WITHOUT WEARING THE APPROPRIATE PERSONAL PROTECTIVE EQUIPMENT AND ASSESSING THE SURROUNDING AREA FOR HAZARDS.

STEP 1 - FITTING A JACK HAMMER

Tools Required:

- 17mm / 5/8" socket
- 19mm / 3/4" socket
- Phillips head screwdriver
- Shifter
- Pliers

Instructions:

1. You should have the parts pictured below:

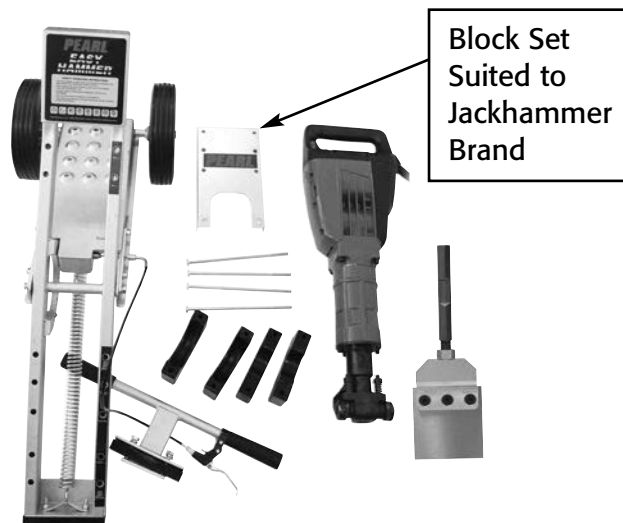

(Jackhammer sold separately)

2. Attach the handle to the frame with the two mounting bolts provided.



3. NOTE – for Block Set details refer to **pg. 10**

Lower trolley to its lowest position and support the end to hold the frame level, then place the base blocks on the frame. Place the jackhammer on top of the base blocks. Ensure the attachment lock on the jackhammer is facing out, as shown in the picture below:



4. Place top blocks and the cover plate on top of the jackhammer and tighten the supplied bolts until they are snug.



5. Mount the jackhammer shank; see jackhammer user manual for details.



Brake Lever Adjustment:

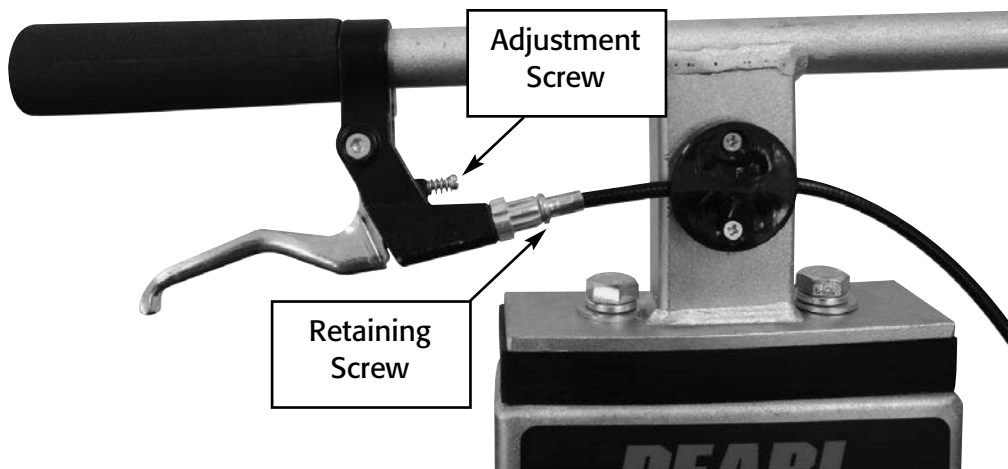

Instructions:

1. Ensure cable is not kinked anywhere along its length.
2. Tighten retaining screw with pliers.
3. Tighten adjustment screw to remove slack from the cable. Note that some slack in the mechanism is normal.



ENSURE THE MACHINE IS SWITCHED OFF BEFORE PLUGGING IN.



ENSURE MOIL IS CORRECTLY INSERTED AND LOCKED IN POSITION BEFORE USE.

STEP 2 - USING THE HAMMER TROLLEY

Instructions:

1. Ensure Hammer is secure in clamping mechanism and cannot rotate.
2. Position and angle before commencing work.

To change angle - lift handles to take weight off lock mechanism then pull the brake lever to disengage the lock mechanism. Lift or lower the height of the handles to achieve the desired angle of jackhammer then release brake lever to reengage the lock mechanism.

3. Never allow Hammer or moil to overheat.
4. Switch on with trigger.
5. Lock into position with trigger lock.
6. Refer to Hammer Instruction Manual for more detail on operation and service.



ALWAYS SWITCH OFF MACHINE BEFORE UNPLUGGING.

STEP 3 - SERVICING THE HAMMER TROLLEY

Every Use:

1. Inspect frame for damage
2. Ensure bolts are secure

Every 6 Months:

1. Adjust brake lever to eliminate free-play
 - See page 7 for details
2. Lubricate brake lever cable
 - Drip oil from the top of the cable so it runs through the cable housing
 - Use light weight oil; grease or heavy oil will clog the cable housings
3. Grease the pivot axle
 - Use a grease gun and apply grease until excess starts to leak out. See picture below for location of grease nipple.

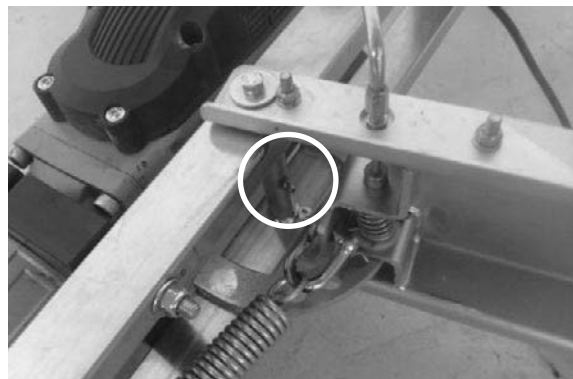

APPENDIX

PARTS BREAKDOWN

For part numbers and specifications please see below.

<i>PART NAME (pcs.)</i>	<i>PART NUMBER</i>
1 M8 SPRING WASHER (3)	PA01M8SW
2 M8 HEX NUT (2)	PA01M8HNLOC
3 M12x50 HEX HEAD BOLT (2)	PA01M12HB
4 M12 WASHER (2)	PA01M12W
5 M12 SPRING WASHER (2)	PA01M12SW
6 M4x12 COUNTERSUNK BOLT (2)	PA01M12HB
7 GREASE NIPPLE (1)	PA01GN
8 M20 NYLON WASHER (6)	PA01M20NW
9 M8 HEX NUT NYLOC (6)	PA01M8HNLOC
10 M8x25 HEX HEAD BOLT (2)	PA01M8HHB
11 M8x20 CSK SOCKET SCREW (4)	PA01M8CSS
12 M8x35mm CSK POZI (2)	PA01M8CSK
13 M8 PLAIN FLAT WASHER (6)	PA01M8PFW
14 TENSION SPRING (1)	PA01SPNG
15 RESTING BLOCK (1)	PA01LOWBL
16 SPRING BRACKET (1)	PA01SPGBRK
17 MAIN FRAME WELDMENT (1)	PA01MFW
18 PIVOT AXLE (1)	PAJHT0401
19 BOLT HOLDER (2)	PA0JHT0402
20 BOLT HOLDER BENT (1)	PA01BHB
21 BASE FRAME WELDMENT (1)	PAJHT0500
22 HANDLE BUFFER (1)	PA01BUFBLK
23 HANDLE NUTBAR (1)	PA01HNB
24 'X' CABLE RETAINER CLIP (1)	PA01CABCL
25 HANDLE FRAME WELDMENT (1)	PA01HDLBAR
27 LOWERING PIN (1)	PAJHT0802
28 SMALL SPRING (1)	PAJHT0803
29 STICKER SET - JHT (1)	PA01STS
30 WHEEL (2)	PA01WHEL
31 WHEEL BUSH (4)	PAJHT9916
32 10mm DIA ANCHOR SHACKLE - 1T (1)	PAJHT99
33 M12 SPRING PLUNGER (1)	PA01M12SP
34 COTTER SPLIT PIN (2)	PA01CSP
35 HANDLE GRIP (2)	PA01HGRP
37 BRAKE LEVER & CABLE (1)	PA01LRCB
38 R-CLIP (1)	PA01RCLIP
39 CABLE LOWER PROTECTOR	PA01CP
40 WHEEL CLIP	PA01WHCL

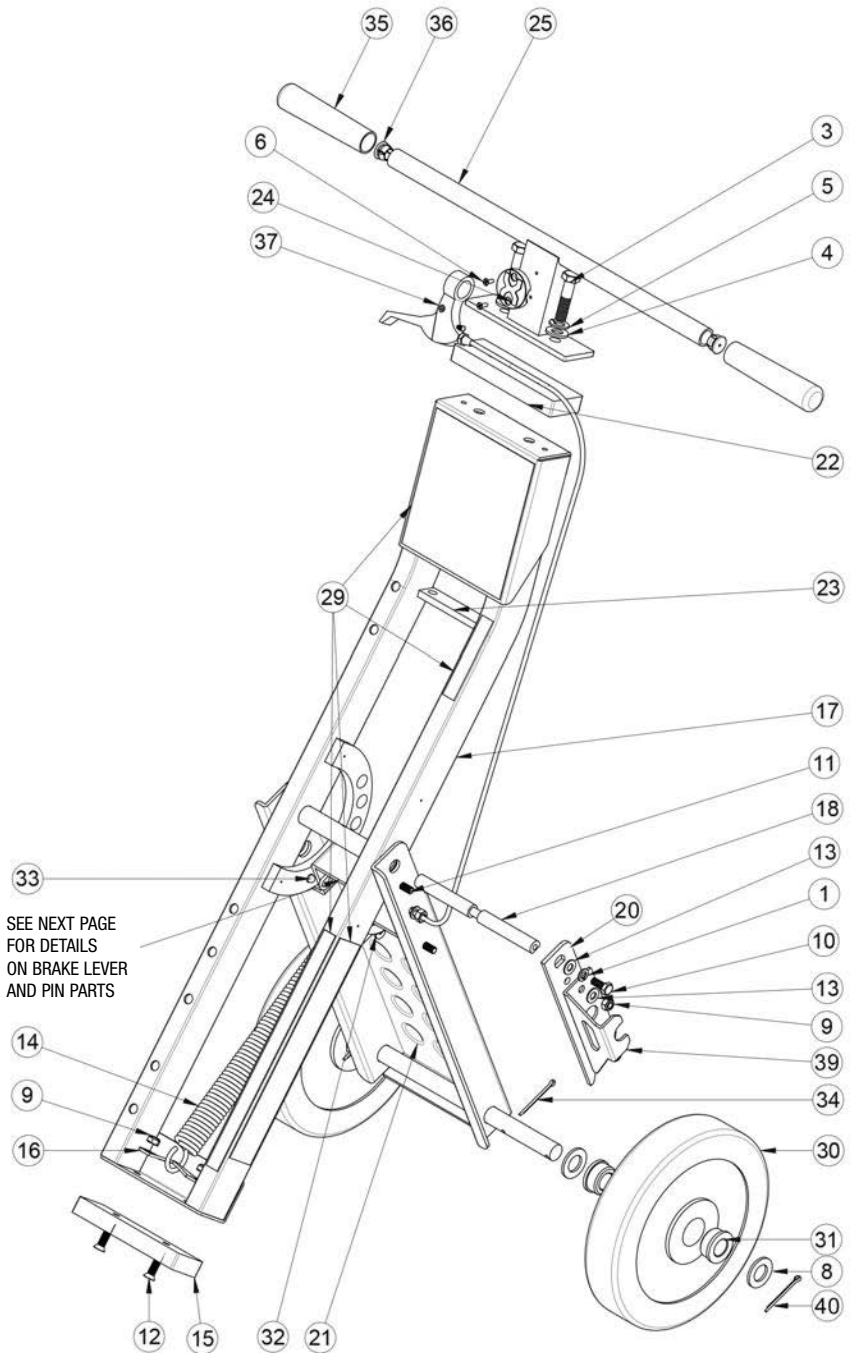

Brake Lever and Pin Parts

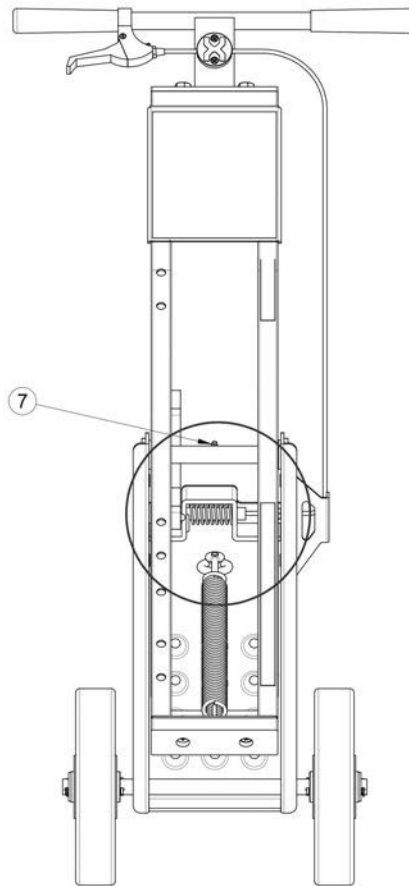
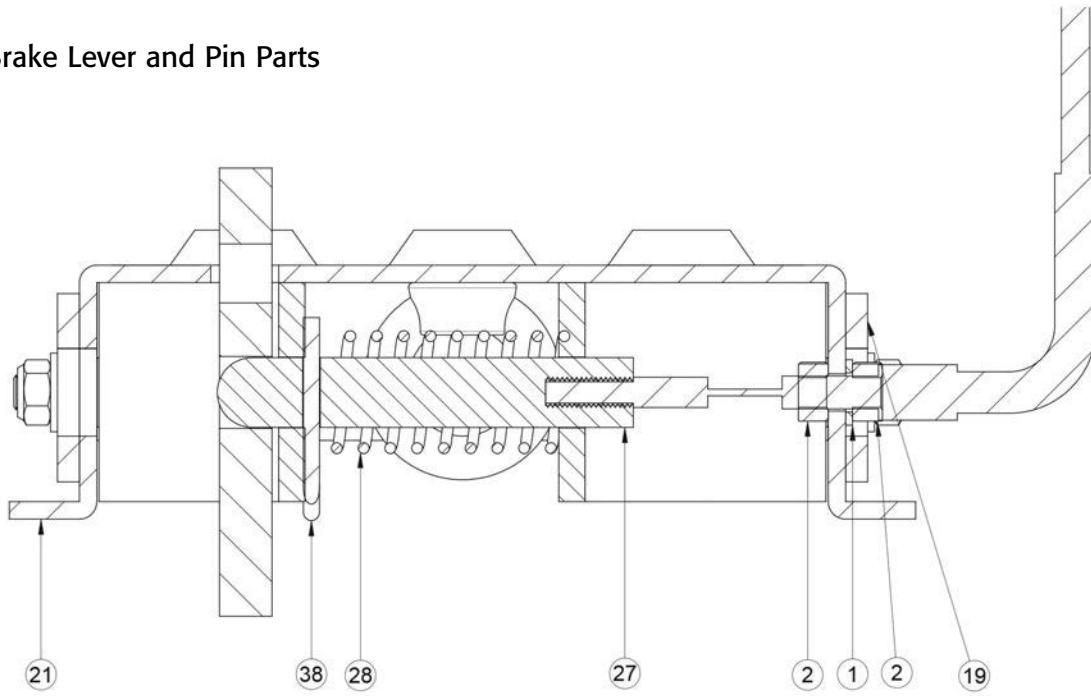

For Block Set,
please see pg. 10

For Tile Strippers,
please see pg. 11

EASY HAMMER® BLOCK SET PART SELECTION

	BACK BLOCK SET	FRONT BLOCK SET	TOP PLATE
BOSCH USA	B + B1	F only	C1
DEWALT	B + B1	F only	C1
HITACHI USA	B + B2	F only	C1
MAKITA	B only	F + F1	C1
MILWAUKEE	B + B2	F only	C1

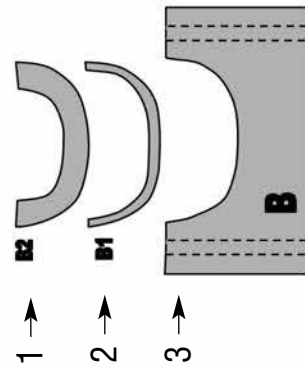
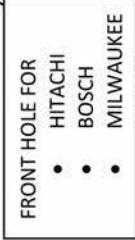
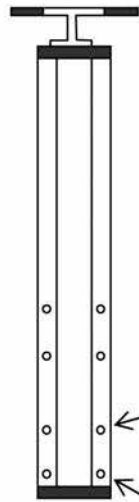
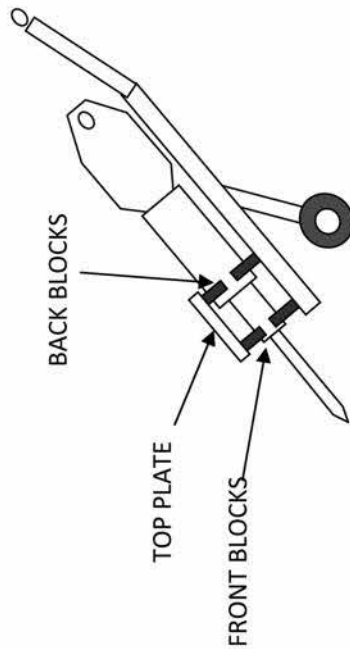

BACK BLOCKS

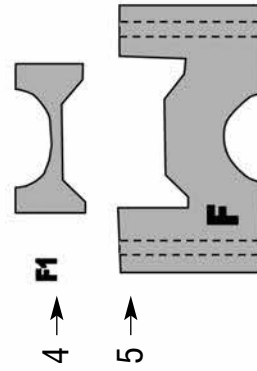

FRONT BLOCKS

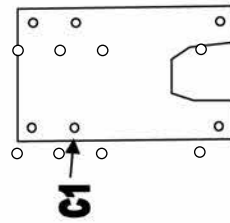

	PART NAME	PART NUMBER
1	PA01HT Complete Block Set	PA01BLMK
2	PA01HT B2 Block	PA01BLKB2
3	PA01HT B1 Block	PA01BLKB1
4	PA01HT B Block	PA01BLKB
5	PA01HT F1 Block	PA01BLKF1
	PA01HT F Block	PA01BLKF
	PA01HTB Lower Block Set	PA01BLBRLW
	PA01HTB Upper Block Set	PA01BLBRUP
	PA01HTH Complete Block Set	PA01BLHL

SALES AND REPAIRS

For sales and spare parts please see below.

CUSTOMER SERVICE

AFTER SALE SERVICE

All customer service (technical questions, re-order of parts, etc.) will be provided by our company. All spare parts for after sales service will be stocked and shipped from our warehouse. If requested, we may arrange for our sales representatives to hold a training class for product knowledge at dealer's location.

HOW TO ORDER PARTS

Please have the following information ready before calling:

- Serial Number
- Model Number
- When purchased and where
- Part Description

All parts listed may be ordered from your Local warehouses. If the part is not stocked locally, call our Corporate office and ask for our Customer Service Department. For Technical Support call **1-800-969-5561**. There is a \$25.00 minimum order.

Return Policy: Return goods for credit or exchange on the basis of the following terms: **(1)** They must be current products; **(2)** Items returned for replacement or refund should be in original cartons and must be accompanied by a packing slip with the following information: Returned Goods Authorization (RGA) number obtainable from Customer Service Department • List of items returned • Reason(s) for return(s) • Copy of original invoice(s); **(3)** Freight charges must be assumed by sender; **(4)** Returning goods are subject to a 15% handling charge to cover our cost of repackaging and restocking. All Prices are subject to change without notice.

Disclaimer: Pearl Abrasive Co. reserves the right to make changes or improvements on its products without incurring an additional obligation including any obligation to make corresponding changes or improvements to products previously manufactured or sold. Pearl reserves the right to discontinue products at any time without notice.

All illustrations displayed in this manual are the property of Pearl Abrasive Co. and shall not be duplicated or reproduced without the express written consent of Pearl Abrasive Co.

Tile Strippers

Heavy duty. Rugged scraper blade for removing tile, linoleum, wood and other floor products. Heavy duty hardened 11" shank and bolts to secure blade in place.



With **THREADED SHANK**

Operator can remove and replace shank unlike the tapered shank.



#PA02TSE
2-piece heavy duty, die-cast machined head. (include shank 1-1/8" hex, head and blade)



#PA02TS
1-piece heavy duty head. (include shank 1-1/8" hex, head and blade)

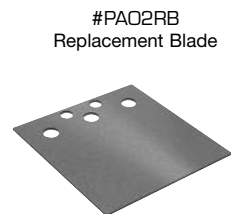

#PA02RB
Replacement Blade

#PA02TSTS
Threaded Shank only

#PA02TSBTS
Nut only

JACK HAMMER MANUAL

Jack Hammer manual will be provided with Jack hammer purchase.

EASY HAMMER®

PEARL®

CORPORATE OFFICE: SO. CALIFORNIA • USA
4900 ZAMBRANO ST., COMMERCE, CA 90040-0031
562-927-5561 • FAX 562-928-3857

800-969-5561

PEARLABRASIVE.COM

GEORGIA • USA
3950 STEVE REYNOLDS BLVD.,
NORCROSS GA 30093

ONTARIO • CANADA
375-2 PIDO ROAD
PETERBOROUGH, ONTARIO K9J-6X7